

## Magistar Combi TI Natural Gas Combi Oven 6GN2/1

ITEM # \_\_\_\_\_

MODEL # \_\_\_\_\_

NAME # \_\_\_\_\_

SIS # \_\_\_\_\_

AIA # \_\_\_\_\_

**218666 (ZCOG62K3G30)**

Magistar Combi TI combi boilerless oven with touch screen control, 6x2/1GN, gas, 2 cooking modes (recipe program, manual), automatic cleaning, 3-glass door

### Short Form Specification

#### Item No.

Combi oven with high resolution full touch screen interface, multilanguage.

- Boilerless steaming function to add and retain moisture.
- AirFlow air distribution system to achieve maximum performance with 7 fan speed levels.
- HP Automatic Cleaning: Automatic and built-in self cleaning system. mettere 4 automatic cycles (short, medium, intensive, rinse) and economizer functions to save energy, water, detergent and rinse aid.
- Cooking modes: Programs (a maximum of 1000 recipes can be stored and organized in 16 different categories); Manual; EcoDelta cooking cycle.
- Special functions: MultiTimer cooking, Cooking Optimizer to cut running costs, Make-it-Mine to customize interface, SoloMio to customize homepage, agenda Calendar, automatic backup mode to avoid downtime.
- USB port to download HACCP data, programs and settings.
- Connectivity for real time access, remote software update, HACCP, recipe and energy management (optional).
- Single sensor core temperature probe.
- Triple-glass door with double LED lights line.
- Stainless steel construction throughout.
- Supplied with n.1 tray rack 2/1 GN, 67 mm pitch.

### Main Features

- Boilerless steaming function to add and retain moisture for high quality, consistent cooking results.
- Dry hot convection cycle (max 300 °C) ideal for low humidity cooking. Automatic moistener (11 settings) for boiler-less steam generation.
- SkyClean: Automatic and built-in self cleaning system with 4 automatic cycles (short, medium, intensive, rinse).
- EcoDelta cooking: cooking with food probe maintaining preset temperature difference between the core of the food and the cooking chamber.
- Programs mode: a maximum of 1000 recipes can be stored in the oven's memory, to recreate the exact same recipe at any time. The recipes can be grouped in 16 different categories to better organize the menu. 16-step cooking programs also available.
- MultiTimer function to manage up to 60 different cooking cycles at the same time, improving flexibility and ensuring excellent cooking results. Can be saved up to 200 MultiTimer programs.
- OptiFlow air distribution system to achieve maximum performance in chilling/heating evenness and temperature control thanks to a special design of the chamber.
- Fan with 7 speed levels from 300 to 1500 RPM and reverse rotation for optimal evenness. Fan stops in less than 5 seconds when door is opened.
- Single sensor core temperature probe included.
- Automatic fast cool down and pre-heat function.
- Back-up mode with self-diagnosis is automatically activated if a failure occurs to avoid downtime.
- Short cleaning cycle: optimized cleaning cycle with a duration of just 33 minutes, improving efficiency and reducing downtime.
- 6-point multi sensor core temperature probe for maximum precision and food safety (optional accessory).
- AirFlow air distribution system to achieve maximum performance in chilling/heating evenness and temperature control thanks to a special design of the chamber combined with high precision variable speed fan.
- HP Automatic Cleaning: automatic and built-in self cleaning system with 4 automatic cycles (short, medium, intensive, rinse) and integrated descale of the steam generator.
- Zanussi Professional recommends the use of treated water to guarantee optimal cooking results and extend the life of the appliance. Check local water condition to select the appropriate water filter. More info available on the website.

### Construction

- Triple thermo-glazed door with 2 hinged inside panels for easy cleaning and double LED lights line.
- Hygienic internal chamber with all rounded corners for easy cleaning.
- 304 AISI stainless steel construction throughout.
- Front access to control board for easy service.
- IPX5 spray water protection certification for easy cleaning.

### User Interface & Data Management

- Connectivity for remote real time access, easy HACCP management, equipment uptime increase, consumption tracking and energy management (requires optional accessory).

APPROVAL: \_\_\_\_\_

- High resolution full touch screen interface (translated in more than 30 languages) - color-blind friendly panel.
- Pictures upload for full customization of cooking cycles.
- Make-it-mine feature to allow full personalization or locking of the user interface.
- USB port to download HACCP data, share cooking programs and configurations. USB port also allows to plug-in sous-vide probe (optional accessory).
- Trainings and guidances supporting materials easily accessible by scanning QR-Code with any mobile device.
- Automatic consumption visualization at the end of the cycle.
- Calendar works as an agenda where the user can plan the daily work and receive personalized alerts for each task.
- SoloMio lets the user group the favorite functions in the homepage for immediate access.

## Sustainability

- Human centered design with 4-star certification for ergonomics and usability.
- The outer cardboard packaging is made from 70% recycled materials and FSC\*-certified paper, printed with eco-friendly, water-based ink to support sustainability and environmental responsibility.

<i>(\*Forest Stewardship Council is the world's leading organization for sustainable forest management).</i>

- C22 and C25 detergents are formulated without phosphates and phosphorus (C25 is also maleic acid-free), making them safe for both the environment and human health.
- Reduced power function for customized slow cooking cycles.
- Triple-glass door minimize your energy loss.\*

\* <i>Approx. -10% of idle energy consumption in convection based on test in compliance with ASTM Standard F2861-20</i>

- <p>Cooking Optimizer function organizes the cooking sequence of the chosen cycles optimizing the work in the kitchen from a time and energy efficiency point of view.</p>
- Cooking Optimizer function organizes the cooking sequence of the chosen cycles optimizing the work in the kitchen from a time and energy efficiency point of view.
- Save energy, water, detergent and rinse aid with green functions.
- Automatic and built-in self cleaning system with 4 automatic cycles (short, medium, intensive, rinse) and integrated descale of the steam generator.

## Optional Accessories

- Water filter with cartridge and flow meter for low steam usage (less than 2 hours of full steam per day) PNC 920004
- Water filter with cartridge and flow meter for medium steam usage PNC 920005
- Wheel kit for 6 & 10 GN 1/1 and 2/1 GN oven base (not for the disassembled one) PNC 922003
- Pair of AISI 304 stainless steel grids, GN 1/1 PNC 922017
- Pair of grids for whole chicken (8 per grid - 1,2kg each), GN 1/1 PNC 922036
- AISI 304 stainless steel grid, GN 1/1 PNC 922062
- AISI 304 stainless steel grid, GN 2/1 PNC 922076
- External side spray unit (needs to be mounted outside and includes support to be mounted on the oven) PNC 922171
- Pair of AISI 304 stainless steel grids, GN 2/1 PNC 922175

- Baking tray for 5 baguettes in perforated aluminum with silicon coating, 400x600x38mm PNC 922189
- Baking tray with 4 edges in perforated aluminum, 400x600x20mm PNC 922190
- Baking tray with 4 edges in aluminum, 400x600x20mm PNC 922191
- Pair of frying baskets PNC 922239
- AISI 304 stainless steel bakery/pastry grid 400x600mm PNC 922264
- Double-step door opening kit PNC 922265
- Grid for whole chicken (8 per grid - 1,2kg each), GN 1/1 PNC 922266
- USB probe for sous-vide cooking PNC 922281
- Kit universal skewer rack and 6 short skewers for Lengthwise GN 2/1 and Crosswise ovens PNC 922325
- Universal skewer rack PNC 922326
- 6 short skewers PNC 922328
- Smoker for lengthwise and crosswise oven PNC 922338
- Multipurpose hook PNC 922348
- 4 flanged feet for 6 & 10 GN , 2", 100-130mm PNC 922351
- Grease collection tray, GN 2/1, H=60 mm PNC 922357
- Grid for whole duck (8 per grid - 1,8kg each), GN 1/1 PNC 922362
- Tray support for 6 & 10 GN 2/1 disassembled open base PNC 922384
- Wall mounted detergent tank holder PNC 922386
- USB single point probe PNC 922390
- IoT module for OnE Connected (combi ovens, blast chiller/freezers, rack type DW) and Match (one IoT board per appliance - to connect oven to the blast chiller for Cook&Chill process). PNC 922421
- Connectivity router (WiFi and LAN) PNC 922435
- Steam optimizer PNC 922440
- Grease collection kit for GN 1/1-2/1 cupboard base (trolley with 2 tanks, open/close device for drain) PNC 922450
- Grease collection kit for GN 1/1-2/1 open base (2 tanks, open/close device for drain) PNC 922451
- Grease collection kit for ovens GN 1/1 & 2/1 (2 plastic tanks, connection valve with pipe for drain) PNC 922452
- Grease collection kit for stacked ovens 6 GN on 6 GN 1/1 - 2/1, with riser PNC 922453
- Slide-in rack with handle for 6 & 10 GN 2/1 oven PNC 922605
- Tray rack with wheels, 5 GN 2/1, 80mm pitch PNC 922611
- Open base with tray support for 6 & 10 GN 2/1 oven PNC 922613
- Cupboard base with tray support for 6 & 10 GN 2/1 oven PNC 922616
- Hot cupboard base with tray support for 6 & 10 GN 2/1 oven holding GN 2/1 trays PNC 922617
- External connection kit for liquid detergent and rinse aid PNC 922618
- Stacking kit for 6X2/1 GN oven on gas 6X2/1 GN oven PNC 922624
- Stacking kit for 6 GN 2/1 oven placed on gas 6 GN 2/1 oven PNC 922625
- Trolley for slide-in rack for 6 & 10 GN 2/1 oven and blast chiller freezer PNC 922627

• Trolley for mobile rack for 6 GN 2/1 on 6 or 10 GN 2/1 ovens	PNC 922631	<input type="checkbox"/>	• Aluminum grill, GN 1/1	PNC 925004	<input type="checkbox"/>
• Riser on feet for stacked 2x6 GN 1/1 ovens	PNC 922633	<input type="checkbox"/>	• Frying pan for 8 eggs, pancakes, hamburgers, GN 1/1	PNC 925005	<input type="checkbox"/>
• Riser on wheels for stacked 2x6 GN 2/1 ovens, height 250mm	PNC 922634	<input type="checkbox"/>	• Flat baking tray with 2 edges, GN 1/1	PNC 925006	<input type="checkbox"/>
• Stainless steel drain kit for 6 & 10 GN oven, dia=50mm	PNC 922636	<input type="checkbox"/>	• Potato baker for 28 potatoes, GN 1/1	PNC 925008	<input type="checkbox"/>
• Plastic drain kit for 6 & 10 GN oven, dia=50mm	PNC 922637	<input type="checkbox"/>	• Kit of 6 non-stick universal pans, GN 1/1, H=20mm	PNC 925012	<input type="checkbox"/>
• Wall support for 6 GN 2/1 oven	PNC 922644	<input type="checkbox"/>	• Kit of 6 non-stick universal pans, GN 1/1, H=40mm	PNC 925013	<input type="checkbox"/>
• Dehydration tray, GN 1/1, H=20mm	PNC 922651	<input type="checkbox"/>	• Kit of 6 non-stick universal pan GN 1/1, H=60mm	PNC 925014	<input type="checkbox"/>
• Flat dehydration tray, GN 1/1	PNC 922652	<input type="checkbox"/>			
• Open base for 6 & 10 GN 2/1 oven, disassembled - NO accessory can be fitted with the exception of 922384	PNC 922654	<input type="checkbox"/>			
• Heat shield for 6 GN 2/1 oven	PNC 922665	<input type="checkbox"/>			
• Heat shield-stacked for ovens 6 GN 2/1 on 6 GN 2/1	PNC 922666	<input type="checkbox"/>			
• Heat shield-stacked for ovens 6 GN 2/1 on 10 GN 2/1	PNC 922667	<input type="checkbox"/>			
• Kit to convert from natural gas to LPG	PNC 922670	<input type="checkbox"/>			
• Kit to convert from LPG to natural gas	PNC 922671	<input type="checkbox"/>			
• Flue condenser for gas oven	PNC 922678	<input type="checkbox"/>			
• Kit to fix oven to the wall	PNC 922687	<input type="checkbox"/>			
• 4 high adjustable feet for 6 & 10 GN ovens, 100-115MM	PNC 922688	<input type="checkbox"/>			
• Tray support for 6 & 10 GN 2/1 oven base	PNC 922692	<input type="checkbox"/>			
• Detergent tank holder for open base	PNC 922699	<input type="checkbox"/>			
• Tray rack with wheels, 6 GN 2/1, 65mm pitch	PNC 922700	<input type="checkbox"/>			
• Chimney adaptor needed in case of conversion of 6 GN 1/1 or 6 GN 2/1 ovens from natural gas to LPG	PNC 922706	<input type="checkbox"/>			
• Mesh grilling grid, GN 1/1	PNC 922713	<input type="checkbox"/>			
• Probe holder for liquids	PNC 922714	<input type="checkbox"/>			
• Exhaust hood with fan for 6 & 10 GN 2/1 GN ovens	PNC 922729	<input type="checkbox"/>			
• Exhaust hood with fan for stacking 6+6 or 6+10 GN 2/1 ovens	PNC 922731	<input type="checkbox"/>			
• Exhaust hood without fan for 6&10x2/1 GN oven	PNC 922734	<input type="checkbox"/>			
• Exhaust hood without fan for stacking 6+6 or 6+10 GN 2/1 ovens	PNC 922736	<input type="checkbox"/>			
• 4 high adjustable feet for 6 & 10 GN ovens, 230-290mm	PNC 922745	<input type="checkbox"/>			
• Tray for traditional static cooking, H=100mm	PNC 922746	<input type="checkbox"/>			
• Double-face griddle, one side ribbed and one side smooth, 400x600mm	PNC 922747	<input type="checkbox"/>			
• Hood Hopper to directly connect the Hood to the centralized ventilation system, for Standard Hoods (with fan motor) and Hoods without fan motor	PNC 922751	<input type="checkbox"/>			
• Trolley for grease collection kit	PNC 922752	<input type="checkbox"/>			
• Water inlet pressure reducer	PNC 922773	<input type="checkbox"/>			
• Non-stick universal pan, GN 1/1, H=20mm	PNC 925000	<input type="checkbox"/>			
• Non-stick universal pan, GN 1/1, H=40mm	PNC 925001	<input type="checkbox"/>			
• Non-stick universal pan, GN 1/1, H=60mm	PNC 925002	<input type="checkbox"/>			
• Double-face griddle, one side ribbed and one side smooth, GN 1/1	PNC 925003	<input type="checkbox"/>			

**Front**

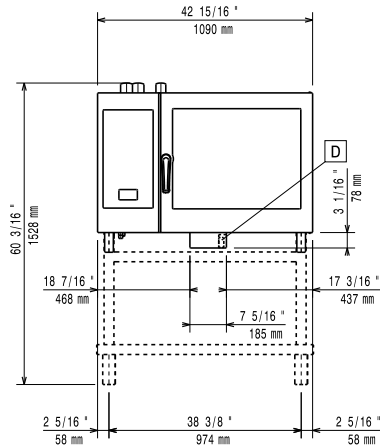

**Side**

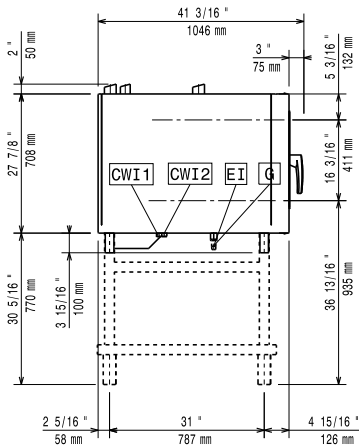

- CWI1** = Cold Water inlet 1 (cleaning)
- CWI2** = Cold Water Inlet 2 (steam generator)
- D** = Drain
- DO** = Overflow drain pipe
- EI** = Electrical inlet (power)
- G** = Gas connection

**Top**  
5'

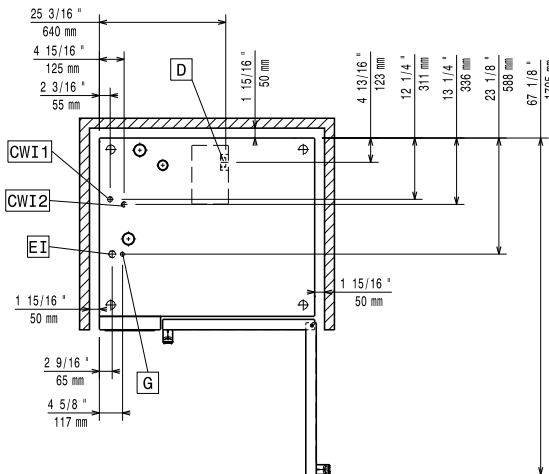

**Electric**

Supply voltage:	220-240 V/1 ph/50 Hz
Electrical power, max:	1.5 kW
Electrical power, default:	1.5 kW

**Gas**

Total thermal load:	96560 BTU (24 kW)
Gas Power:	24 kW
Standard gas delivery:	Natural Gas G20
ISO 7/1 gas connection diameter:	1/2" MNPT

**Water:**

Inlet water temperature, max:	30 °C
Inlet water pipe size (CWI1, CWI2):	3/4"
Pressure, min-max:	1-6 bar
Chlorides:	<10 ppm
Conductivity:	>50 µS/cm
Drain "D":	50mm

**Capacity:**

Trays type:	6 (GN 2/1)
Max load capacity:	60 kg

**Key Information:**

Door hinges:	Right Side
External dimensions, Width:	1090 mm
External dimensions, Depth:	971 mm
External dimensions, Height:	808 mm
Weight:	176 kg
Net weight:	153 kg
Shipping weight:	176 kg
Shipping volume:	1.28 m <sup>3</sup>

**ISO Certificates**

ISO Standards:	ISO 9001; ISO 14001; ISO 45001; ISO 50001
----------------	---